

How to build a barrel

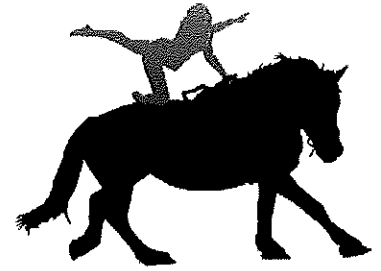

1. Uses of a Vaulting Barrel

- A. It can serve as a surrogate horse for groups starting without a horse.
- B. It can save the horse from over-use by providing another means for vaulters to practice.
- C. It can save time as vaulters continue their lesson on the barrel during the horse's warm-up and rest periods, and during other vaulters' turns on the horse.
- D. It can help vaulters gain confidence since they can master the exercises on a stationary object before trying them on a moving horse.
- E. It can be used indoors during bad weather so that the vaulting lessons need not be canceled when the horse cannot be worked.
- F. It can be used by vaulters who are composing freestyles and want to experiment with different combinations of exercises.

2. Construction of Barrel

- A. A vaulting barrel can be constructed from two 55-gallon oil drums mounted on legs. Barrels may also be designed from plywood and one-by-fours.
- B. The barrel must be solid enough so that it will not tip over when vaulters pull on the handles.
- C. The barrel must be well padded and the handles wrapped with tape. Sharp edges, rough spots, or protruding barrel legs are a danger to the vaulters and must be avoided.

3. Footing around Barrel

- A. The footing around the barrel is as important as that in the vaulting circle.
- B. Gymnastic mats or foam rubber provide for good landings.
- C. The same types of footing (turf, sand, shavings, etc.) as used in the vaulting circle are also suitable for use around the barrel, especially if it is located in the same general area.

BARREL SPECIFICATIONS

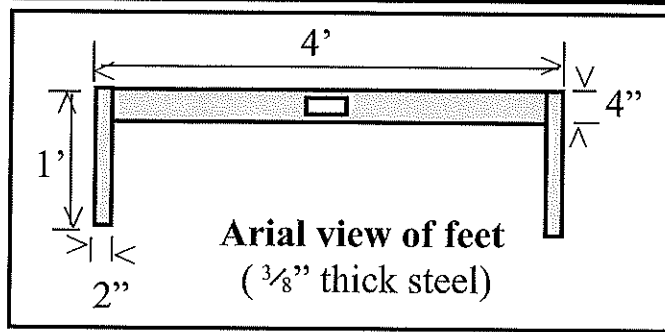
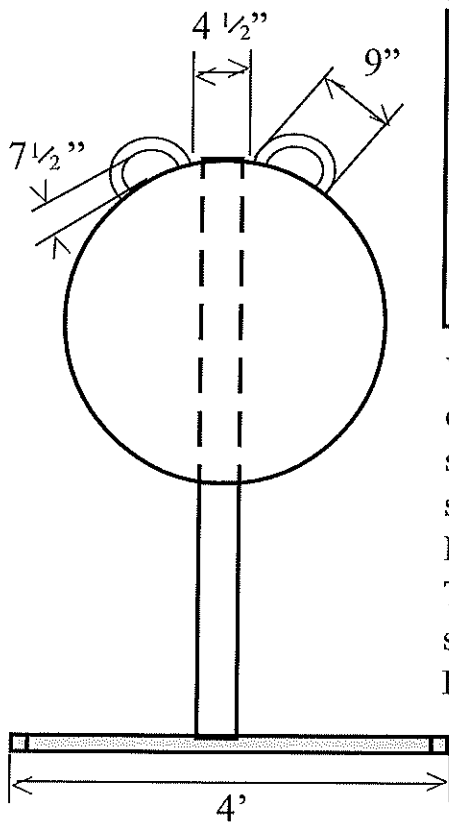

Vaulting barrels must be situated in an area clear of impediments (overhead and to the sides). The ground must be level, soft and springy.

Legs must not project beyond sides of barrel. The feet must be covered and it is best to secure them to the ground.

Handles are vertical.

Dimensions here are given without padding.

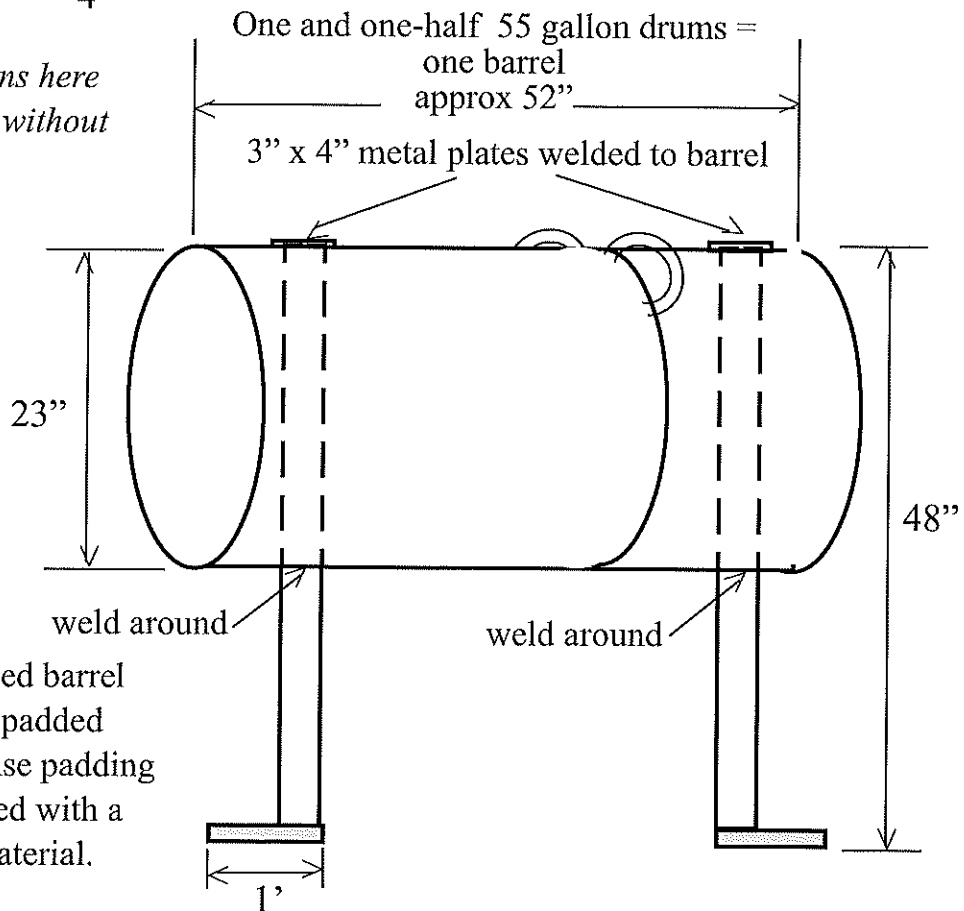

The finished barrel should be padded with a dense padding and covered with a durable material.